

Series HSC-S Pumps

B-512H

 **Bell & Gossett**
a xylem brand

TABLE OF CONTENTS

Useful Pump Formulas	2
Performance Curves	3
Materials of Construction (Standard)	4
Materials of Construction (Optional)	5
Pump Dimensions	6, 7

USEFUL PUMP FORMULAS

Pressure (PSI)	=	$\frac{\text{Head (Feet)} \times \text{Specific Gravity}}{2.31}$
Head (Feet)	=	$\frac{\text{Pressure (PSI)} \times 2.31}{\text{Specific Gravity}}$
Vacuum (Inches of Mercury)	=	Dynamic Suction Lift (Feet) x .883 x Specific Gravity
Horsepower (Brake)	=	$\frac{\text{GPM} \times \text{Head (Feet)} \times \text{Specific Gravity}}{3960 \times \text{Pump Efficiency}}$
Horsepower (Water)	=	$\frac{\text{GPM} \times \text{Head (Feet)} \times \text{Specific Gravity}}{3960}$
Efficiency (Pump)	=	$\frac{\text{Horsepower (Water)}}{\text{Horsepower (Brake)}} \times 100 \text{ Per Cent}$
NPSH (Available)	=	Positive Factors – Negative Factors

Affinity Laws: Effect of change of speed or impeller diameter on centrifugal pumps.

	GPM Capacity	Ft. Head	BHP
Impeller Diameter Change	$Q_2 = \frac{D_2}{D_1} Q_1$	$H_2 = \left(\frac{D_2}{D_1}\right)^2 H_1$	$P_2 = \left(\frac{D_2}{D_1}\right)^3 P_1$
Speed Change	$Q_2 = \frac{\text{RPM}_2}{\text{RPM}_1} Q_1$	$H_2 = \left(\frac{\text{RPM}_2}{\text{RPM}_1}\right)^2 H_1$	$P_2 = \left(\frac{\text{RPM}_2}{\text{RPM}_1}\right)^3 P_1$

Where Q = GPM, H = Head, P = BHP, D = Impeller Dia., RPM = Pump Speed

PERFORMANCE CURVES – SERIES HSC-S

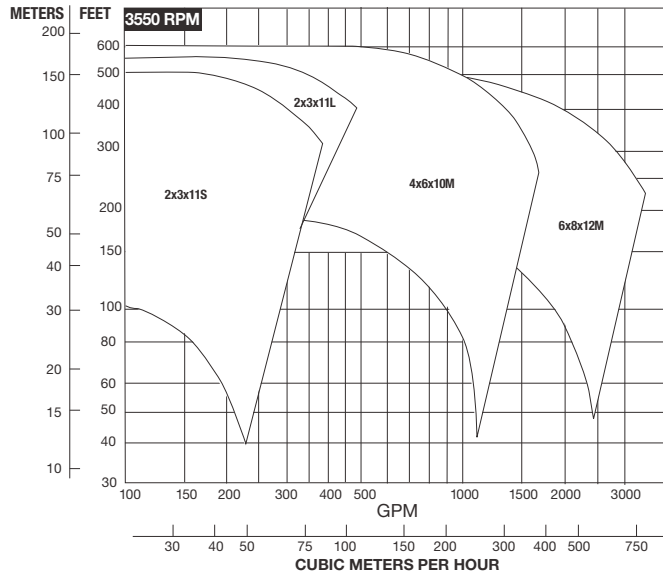
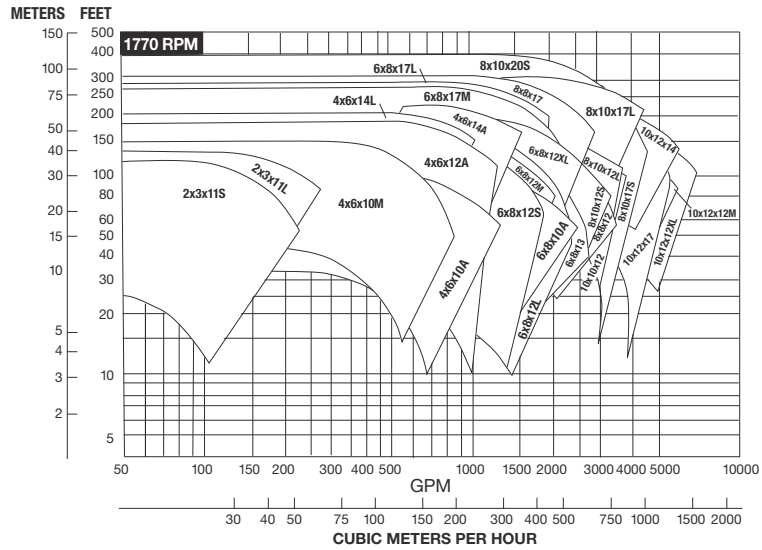
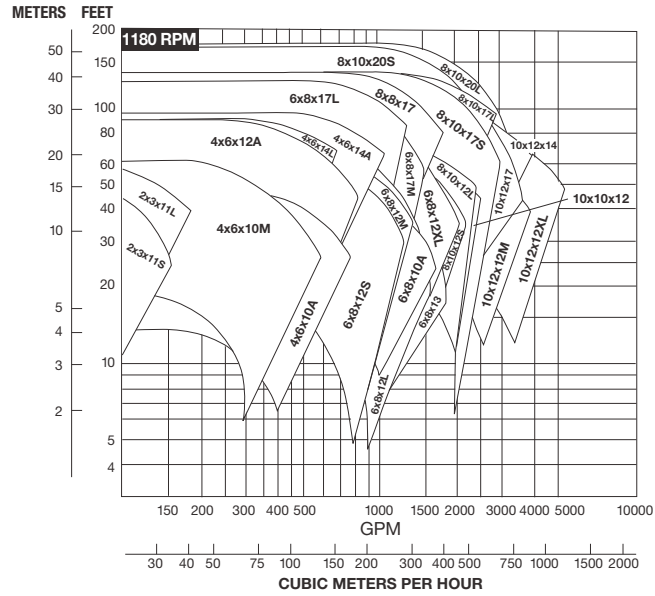

SERIES HSC-S MATERIALS OF CONSTRUCTION

MECHANICAL SEALS MOUNTED ON SHAFT

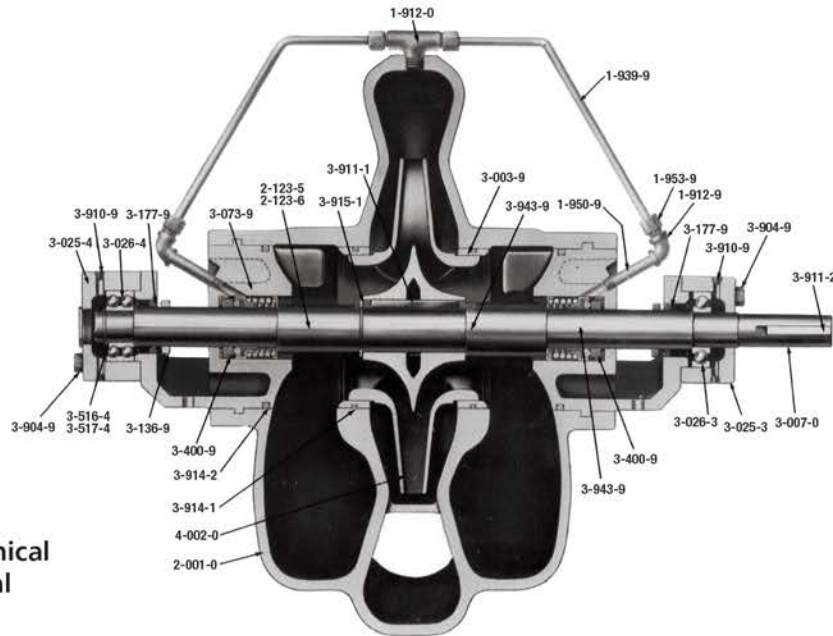

Standard Mechanical Seal with External Seal Piping.

NO.	DESCRIPTION	MATERIAL
		Cast Iron, Bronze Fitted
1-912-0	Pipe Fitting (Casing)	Brass
1-912-9	90° Elbow	Malleable Iron
1-939-9	Tubing	Copper
1-950-9	Nipple	Malleable Iron
1-953-9	Male Connector	Brass
2-001-0	Casing Assembly 2	Cast Iron (ASTM A48 Class 35A)
2-123-5	Casing Joint Gasket (Suction)	Paper (Vellumoid 505)
2-123-6	Casing Joint Gasket (Discharge)	Paper (Vellumoid 505)
3-003-9	Casing Ring	Bronze (ASTM B584-932)
3-007-0	Shaft	416 Stn. Stl.
3-025-3	Bearing Housing	Cast Iron (ASTM A48 Class 25A)
3-025-4	Bearing Housing	Cast Iron (ASTM A48 Class 25A)
3-026-3	Bearing (Inboard) Ball	Steel
3-026-4	Bearing (Outboard) Ball	Steel
3-073-9	Stuffing Box (Mechanical Seal)	Cast Iron (ASTM A48 Class 25A)
3-136-9	Deflector	Rubber (BUNA "N")
3-177-9	Lip Seal (Bearing)	Rubber (BUNA "N")
3-400-9	Mechanical Seal (See copy at right)	Stn. Stl., Rubber, Carbon, Ceramic
3-904-9	Capscrew (Bearing Housing)	Steel, Grade 2
3-910-9	Pipe Plugs (Bearing Housing)	Steel
3-911-1	Key, Impeller	Stn., Stl. (ANSI 416)
3-911-2	Key, Coupling	Steel
3-914-1	"O" Ring (Casing Ring)	Rubber (Buna "N")
3-914-2	"O" Ring (Stuffing Box)	Rubber (Buna "N")
3-915-1	Retaining Ring (Impeller)	Steel
3-516-4	Locknut (Bearing)	Steel
3-517-4	Lockwasher (Bearing)	Steel
3-943-9	Spirol Pin (Stuffing Box) 1	304 SS
3-943-9	Spirol Pin (Casing Ring) 1	304 SS
4-002-0	Impeller	Bronze (ASTM B584-876)
OPTIONAL COMPONENTS*		
4-004-9	Rings, Impeller	Bronze (ASTM B505-925)

MECHANICAL SEALS

STANDARD CONSTRUCTION:

175 PSIG (12 BAR)
Maximum Working Pressure
*100 PSIG (7 BAR) Maximum Suction Pressure
125#FF ANSI FLANGE (ANSI A21.10, AWWA C110 and ANSI B16.1 class 125)
Type 21, Buna/Carbon-Ceramic, *100 psig (7 bar) maximum suction pressure, from -20 to 225°F (-29 to 107°C)

Optional Seals:

Type 21, EPR/Carbon-Ceramic, *100 psig (7 bar) maximum suction pressure, from -20 to 250°F (-29 to 121°C)
Type 21, EPR/Carbon-Tungsten Carbide, *100 psig (7 bar) maximum suction pressure, from -20 to 250°F (-29 to 121°C)

OPTIONAL CONSTRUCTION:

280 PSIG (19 BAR) Maximum Working Pressure
200 PSIG Maximum Suction Pressure
250#FF ANSI FLANGE (ANSI B16.1 class 250 except flanges are flat faced)
Type 1, Buna/Carbon-Ceramic, 150 psig (10 bar) maximum suction pressure, from -20 to 225°F (-29 to 107°F)

Optional Seals:

Type 1, EPR/Carbon-Ceramic, 150 psig (10 bar) maximum suction pressure, from -20 to 250°F (-29 to 121°C)
Type 1, EPR/Carbon-Tungsten Carbide, 200 psig (13 bar) maximum suction pressure, from -20 to 250°F (-29 to 121°C)

400 PSIG (27 BAR) Maximum Working Pressure
300 PSIG Maximum Suction Pressure
250#FF ANSI FLANGE (ANSI B16.1 class 250 except flanges are flat faced)
Type 1B, Buna/Carbon-Ceramic, 300 psig (20 bar) maximum suction pressure, from -20 to 225°F (-29 to 107°F)

Optional Seals:

Type 1B, EPR/Carbon-Ceramic, 300 psig (20 bar) maximum suction pressure, from -20 to 250°F (-29 to 121°C)
Type 1B, EPR/Carbon-Tungsten Carbide, 300 psig (20 bar) maximum suction pressure, from -20 to 250°F (-29 to 121°C)

*Maximum suction pressure for 3500 RPM is 85 psig (6 bar).

*Optional modifications available, if specified, at extra cost.

1 Located at casing parting line.
2 280 and 400 psi 6x8x10A is cast iron.
(Note: Mechanical seals on shaft arrangement not available on pump sizes 6x8x12M, 8x10x20S, and 8x10x20L.)

Note: For pumps with 400 PSI working pressure, wear ring clearances are doubled. Derate pump efficiencies by 2 percentage points.

SERIES HSC-S MATERIALS OF CONSTRUCTION

MECHANICAL SEALS MOUNTED ON SLEEVE

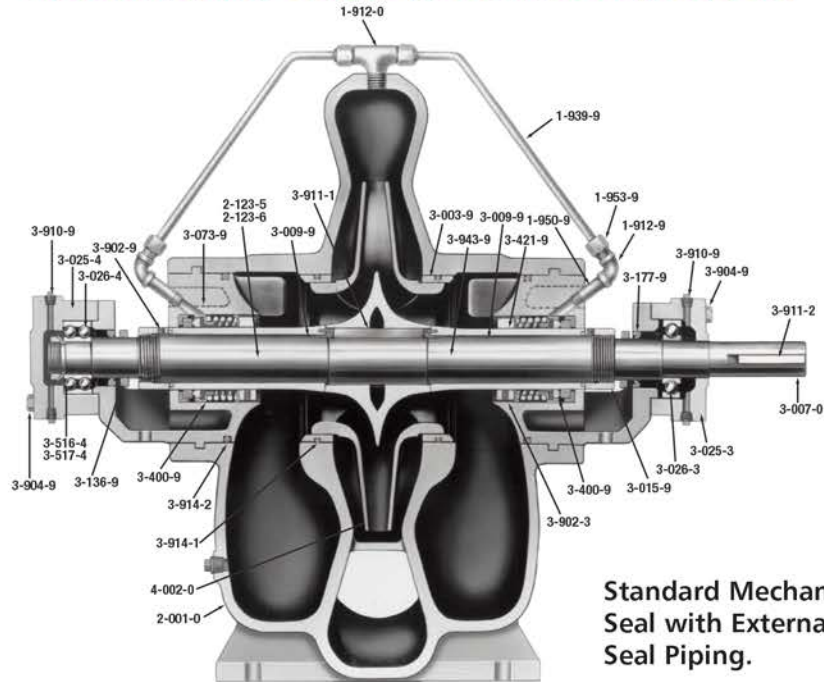

Standard Mechanical Seal with External Seal Piping.

NO.	DESCRIPTION	MATERIAL
		Cast Iron, Bronze Fitted
1-912-0	Pipe Fitting (Casing)	Brass
1-912-9	90° Elbow	Malleable Iron
1-939-9	Tubing	Copper
1-950-9	Nipple	Malleable Iron
1-953-9	Male Connector	Brass
2-001-0	Casing Assembly ³	Cast Iron (ASTM A48 Class 35A)
2-123-5	Casing Joint Gasket (Suction)	Paper (Vellumoid 505)
2-123-6	Casing Joint Gasket (Discharge)	Paper (Vellumoid 505)
3-003-9	Casing Ring	Bronze (ASTM B584-932)
3-007-0	Shaft ⁴	Steel (SAE 1045)
3-009-9	Shaft Sleeve ⁵	Bronze (ASTM B584-932)
3-015-9	Shaft Sleeve Nut	Bronze (ASTM B584-932)
3-902-9	Screw, Locking (Set Screw)	Steel
3-025-3	Bearing Housing	Cast Iron (ASTM A48 Class 25A)
3-025-4	Bearing Housing	Cast Iron (ASTM A48 Class 25A)
3-026-3	Bearing (Inboard) Ball	Steel
3-026-4	Bearing (Outboard) Ball	Steel
3-073-9	Stuffing Box (Mechanical Seal)	Cast Iron (ASTM A48 Class 25A)
3-136-9	Deflector	Rubber (BUNA "N")
3-177-9	Lip Seal (Bearing)	Rubber (BUNA "N")
3-400-9	Mechanical Seal (See copy at right)	Stn. Stl., Rubber, Carbon, Ceramic
3-421-9	Set Collar	Bronze (ASTM B584-932)
3-902-3	Set Screw	304 SS
3-904-9	Capscrew (Bearing Housing)	Steel, Grade 2
3-910-9	Pipe Plugs (Bearing Housing)	Steel
3-911-1	Key, Impeller	Steel
3-911-2	Key, Coupling	Steel
3-914-1	"O" Ring (Casing Ring)	Rubber (Buna "N")
3-914-2	"O" Ring (Stuffing Box)	Rubber (Buna "N")
3-516-4	Locknut (Bearing)	Steel
3-517-4	Lockwasher (Bearing)	Steel
3-943-9	Spirol Pin (Stuffing Box) ¹	304 SS
3-943-9	Spirol Pin (Casing Ring) ¹	304 SS
4-002-0	Impeller	Bronze (ASTM B584-876)

MECHANICAL SEALS

STANDARD CONSTRUCTION:

175 PSIG (12 BAR)
Maximum Working Pressure
*100 PSIG (7 BAR) Maximum Suction Pressure
125#FF ANSI FLANGE (ANSI A21.10, AWWA C110 and ANSI B16.1 class 125)
Type 21, Buna/Carbon-Ceramic, *100 psig (7 bar) maximum suction pressure, from -20 to 225°F (-29 to 107°C)

Optional Seals:

Type 21, EPR/Carbon-Ceramic, *100 psig (7 bar) maximum suction pressure, from -20 to 250°F (-29 to 121°C)
Type 21, EPR/Carbon-Tungsten Carbide, *100 psig (7 bar) maximum suction pressure, from -20 to 250°F (-29 to 121°C)
Packing, *100 psig (7 bar) maximum working pressure, 0 to 225°F (-18 to 107°C)

OPTIONAL CONSTRUCTION:

280 PSIG (19 BAR) Maximum Working Pressure
200 PSIG Maximum Suction Pressure
250#FF ANSI FLANGE (ANSI B16.1 class 250 except flanges are flat faced)
Type 1, Buna/Carbon-Ceramic, 150 psig (10 bar) maximum suction pressure, from -20 to 225°F (-29 to 107°F)

Optional Seals:

Type 1, EPR/Carbon-Ceramic, 150 psig (10 bar) maximum suction pressure, from -20 to 250°F (-29 to 121°C)
Type 1, EPR/Carbon-Tungsten Carbide, 200 psig (13 bar) maximum suction pressure, from -20 to 250°F (-29 to 121°C)

400 PSIG (27 BAR) Maximum Working Pressure
300 PSIG Maximum Suction Pressure
250#FF ANSI FLANGE (ANSI B16.1 class 250 except flanges are flat faced)
Type 1B, Buna/Carbon-Ceramic, 300 psig (20 bar) maximum suction pressure, from -20 to 225°F (-29 to 107°F)

Optional Seals:

Type 1B, EPR/Carbon-Ceramic, 300 psig (20 bar) maximum suction pressure, from -20 to 250°F (-29 to 121°C)
Type 1B, EPR/Carbon-Tungsten Carbide, 300 psig (20 bar) maximum suction pressure, from -20 to 250°F (-29 to 121°C)

*Maximum suction pressure for 3500 RPM is 85 psig (6 bar).

OPTIONAL COMPONENTS*

4-004-9	Rings, Impeller	Bronze (ASTM B505-925)
3-400-9	Mechanical Seal Balanced	Stn. Stl., Rubber, Carbon, Ceramic

*Optional modifications available, if specified, at extra cost.
1 Located at casing parting line.

3 For 280 and 400 psi working pressures, casing materials is Ductile iron (ASTM A536, Grade 65-45-12).

4 Shaft material AISI 4140 on pump 4x6x11, 6x8x12M, 8x10x20S, 8x10x20L.

5 Mechanical seal on sleeve or packing not available for pump size 6x8x10A.

Note: For pumps with 400 PSI working pressure, wear ring clearances are doubled. Derate pump efficiencies by 2 percentage points.

SERIES HSC-S MODEL 150 DIMENSIONS

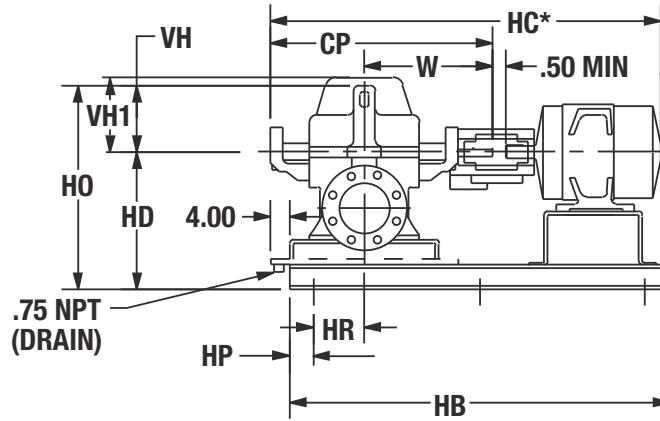
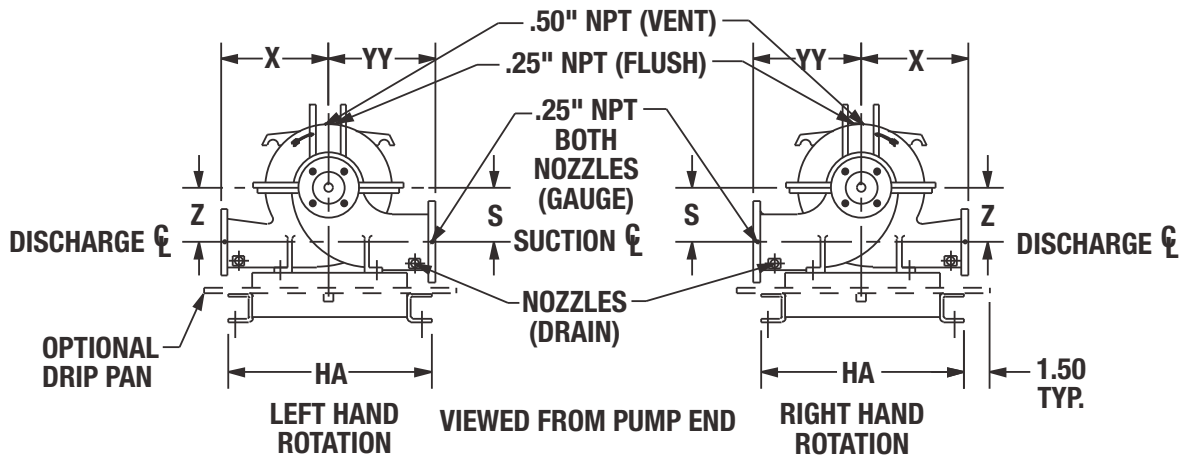

STANDARD: 125#FF ANSI FLANGE (ANSI A21.10, AWWA C110 & ANSI B16.1 CLASS 125)
 OPTIONAL: 250#FF ANSI FLANGE (ANSI B16.1 CLASS 250 EXCEPT FLANGES ARE FLAT FACED)
 VH1 APPLIES TO 280 & 400 PSIG RIBBED CASINGS.
 DIMENSIONS ARE SUBJECT TO CHANGE. NOT TO BE USED FOR CONSTRUCTION PURPOSES UNLESS CERTIFIED.
 *MOTOR DIMENSIONS ARE APPROXIMATE FOR "T" FRAMES, VARY BY MANUFACTURER AND MOTOR TYPE.

SERIES HSC-S MODEL 150 DIMENSIONS

PUMP SIZE	MOTOR FRAME	DIMENSIONS – INCHES (MM)																
		HA	HB	HP	HR	CP	HC* MAX	HD	HO	S & Z	VH	VH1	W	X	YY			
2x3x11 S, L	143-215	20.00	48.00 (1219)	6.00	2.25	28.25	47 (1194)	15.25(388)	22.05 (560)	5.50	6.80	16.00	9.00	10.00				
	254-365	(508)	54.00 (1372)	(152)	(57)	(718)	61 (1549)			(140)	(173)				–	(406)	(229)	(254)
4x6x10A	182-215	21.50	48.00 (1219)	6.00	2.88	30.06	60 (1524)	18.25 (464)	25.94 (659)	7.00	7.69	17.25	11.50	12.00				
	254-324	(546)	60.00 (1524)	(152)	(73)	(764)	69 (1753)			(178)	(195)				–	(438)	(292)	(305)
4x6x10M	182-215	24.00	48.00 (1219)	6.00	4.62	33.12	53 (1346)	18.25 (464)	26.12 (664)	6.50	7.88	18.50	11.50	13.00				
	254-326		58.00 (1473)				63 (1600)											
	364-405		64.00 (1626)				72 (1829)											
	444-445		76.00 (1930)				78 (1981)								20.25 (514)	28.12 (714)		
4x6x12A	215	24.00	48.00 (1219)	6.00	4.62	33.12	53 (1346)	18.25 (464)	26.12 (664)	6.50	7.88	18.50	11.50	13.00				
	254-326		58.00 (1473)				63 (1600)											
	364-365		64.00 (1626)				66 (1677)											
4x6x14A	215-256	24.00	50.00 (1270)	6.00	3.25	30.75	55 (1397)	19.52 (489)	28.50 (723)	7.75	9.20	17.50	11.50	13.00				
	284-365		58.00 (1473)				64 (1626)											
	404-405		68.00 (1727)				70 (1788)											
	444		76.00 (1930)				74 (1880)								21.52 (547)	35.00 (889)		
4x6x14L	182-256	24.00	50.00 (1270)	6.00	3.25	30.75	55 (1397)	19.25 (489)	28.87 (733)	7.75	9.62	17.50	11.50	13.00				
	284-365	(610)	58.00 (1473)	(152)	(83)	(781)	64 (1626)			(197)	(244)				–	(445)	(292)	(330)
6x8x10A	215	24.00	58.00 (1473)	6.00	10.75	40.00	60.25 (1530)	21.25 (540)	30.50 (775)	8.25	9.25	23.00	12.50	12.50				
	254-326		64.00 (1626)				69.25 (1759)											
	364-365		68.00 (1727)				71.25 (1810)											
6x8x12 S, L, XL	182-215	21.50	48.00 (1219)	6.00	3.25	30.75	51 (1296)	21.25 (540)	30.85 (784)	9.00	9.60	17.50	14.00	14.00				
	254-326		54.00 (1372)				61 (1549)											
	364-365		60.00 (1524)				64 (1626)											
	254-326		24.00				58.00 (1473)								6.00	4.63	33.12	63 (1600)
364-405	(610)	64.00 (1626)	72 (1829)															
444-447	76.00 (1930)	81 (2058)	23.25 (591)	32.85 (834)														
6x8x13	254-326	24.00	62.00 (1575)	6.00	5.63	36.87	67 (1702)	20.00 (508)	29.40 (747)	8.00	9.40	21.25	13.00	15.50				
	364-405	(610)	68.00 (1727)	(152)	(143)	(937)	76 (1930)			(203)	(239)				–	(540)	(330)	(394)
6x8x17 M, L	284-326	24.00	62.00 (1575)	6.00	5.63	36.87	67 (1702)	21.25 (540)	33.00 (838)	9.00	11.75	21.25	14.00	16.00				
	364-405		68.00 (1727)				76 (1930)											
	444-445		76.00 (1930)				82 (2083)											
8x8x12	254-326	24.00	62.00 (1575)	6.00	5.63	36.87	67 (1702)	20.00 (508)	30.25 (768)	8.00	10.25	21.25	14.00	16.50				
	364-405	(610)	68.00 (1727)	(152)	(143)	(937)	76 (1930)			(203)	(260)				(299)	(540)	(356)	(419)
8x8x17	324-365	24.00	66.00 (1676)	6.00	7.00	39.56	72 (1829)	21.75 (553)	33.75 (857)	9.50	12.00	13.50	22.56	15.00				
	404-445	(610)	76.00 (1930)	(152)	(178)	(1005)	85 (2159)											
	29.40	747	86.00 (2184)	5.00	8.00	39.56	93 (2362)	23.75 (603)	35.75 (908)	(241)	(305)	(343)	(573)	(381)				
	447-449		86.00 (2184)	(127)	(203)		93 (2362)											
8x10x12 S, L	254-286	24.00	62.00 (1575)	6.00	7.00	39.56	67 (1702)	21.50 (546)	32.00 (813)	8.50	10.50	12.00	22.56	14.00				
	324-365		(610)				66.00 (1676)								(152)	(178)	(1005)	72 (1829)
	404-445		76.00 (1930)				5.00								8.00	85 (2159)	23.50 (597)	34.00 (864)
8x10x17 S, L	324-365	24.00	66.00 (1676)	6.00	7.00	39.56	72 (1829)	23.25 (591)	36.06 (916)	10.00	12.81	14.31	22.56	16.00				
	404-445	(610)	76.00 (1930)	(152)	(178)	(1005)	85 (2159)											
	447-449	747	86.00 (2184)	5.00	8.00	93 (2362)	25.25 (641)	38.06 (967)										
8x10x20 S, L	324-365	26.00	66.00 (1676)	6.00	7.00	39.56	72 (1829)	27.25 (692)	49.50 (1257)	14.00	15.44	22.25	18.00	20.00				
	404-445	(660)	76.00 (1930)	(152)	(178)	(1005)	85 (2159)											
	447-449	798	86.00 (2184)	5.00	8.00	93 (2362)	29.25 (743)	51.50 (1308)										
10x10x12	284-365	24.00	68.00 (1727)	6.00	8.50	42.56	75 (1905)	22.50 (572)	33.69 (856)	9.00	11.19	24.06	16.00	18.00				
	404-445	(610)	80.00 (2032)	(152)	(216)	(1081)	96 (2438)											
10x12x12 M, XL	284-365	24.00	68.00 (1727)	6.00	8.50	42.56	75 (1905)	24.50 (622)	36.00 (914)	10.00	11.50	24.06	16.00	19.00				
	404-445	(610)	80.00 (2032)	(152)	(216)	(1081)	96 (2438)											
	447-449	747	86.00 (2184)	5.00	8.00	93 (2362)	25.25 (641)	38.69 (983)										
10x12x14	324-365	24.00	66.00 (1676)	6.00	7.00	39.56	72 (1829)	25.25 (641)	38.69 (983)	11.00	13.44	14.94	22.56	18.00				
	404-445	(610)	76.00 (1930)	(152)	(178)	(1005)	85 (2159)											
	447-449	747	86.00 (2184)	5.00	8.00	93 (2362)	27.25 (692)	40.69 (1034)										
10x12x17	324-365	24.00	66.00 (1676)	6.00	7.00	39.56	72 (1829)	25.25 (641)	38.69 (983)	11.00	13.44	14.94	22.56	18.00				
	404-445	(610)	76.00 (1930)	(152)	(178)	(1005)	85 (2159)											
	447-449	747	86.00 (2184)	5.00	8.00	93 (2362)	27.25 (692)	40.69 (1034)										

Xylem |'zīləm|

- 1) The tissue in plants that brings water upward from the roots;
- 2) a leading global water technology company.

We're 12,700 people unified in a common purpose: creating innovative solutions to meet our world's water needs. Developing new technologies that will improve the way water is used, conserved, and re-used in the future is central to our work. We move, treat, analyze, and return water to the environment, and we help people use water efficiently, in their homes, buildings, factories and farms. In more than 150 countries, we have strong, long-standing relationships with customers who know us for our powerful combination of leading product brands and applications expertise, backed by a legacy of innovation.

For more information on how Xylem can help you, go to www.xyleminc.com



Xylem Inc.
8200 N. Austin Avenue
Morton Grove, Illinois 60053
Phone: (847) 966-3700
Fax: (847) 965-8379
www.bellgossett.com